

MAGIS

Magis @ Milano Design Week
07 / 12 June 2022

Press Release

Salone del Mobile
Hall 20 / Stand C11_D08

Showroom
Corso Garibaldi, 77

Tuesday - Saturday
h 10am / 09pm
Sunday
h 10am / 06pm

#magis #magisofficial



MAGIS

Magis @ Milano Design Week
07 / 12 June 2022



MAGIS
=
MORE THAN



2020



2014



2011



2008

MAGIS

Magis @ Milano Design Week
07 / 12 June 2022



SUSTAINABILITY CATALOG

MAGIS

Magis @ Milano Design Week
07 / 12 June 2022



Salone del Mobile 2022

Magis means “home”. An unconventional home that, during the Salone del Mobile 2022, opens its door to a world of living spaces made of uncompromising design.

The 500-m² stand in Hall 20 is the setting for the Magis house: many new entries, from the Officina bookcase to the Tambour coffee tables in the new version with top in gres by Ronan & Erwan Bouroullec, from Philippe Starck’s Big Will table in a brand-new version, to the Alpina chair, an archetype of sustainability, by Barber Osgerby, from Ron Gilad’s Swing partition, to the AKA stool designed by Konstantin Grcic, from the new low tables part of the Costume sofa modular system designed by Stefan Diez to the brand new Riace Sofa designed by the Bouroullecs, equally sculptural and sinuous.

But the absolute star of the show is Stefan Diez’s Costume sofa. Flanked by the newly added low tables in aluminium plate, it greets visitors at the entrance, showcased in its twin souls – Home and Contract – as reflected in the different fittings and fabrics. The upholstered furniture is a recent addition to the Magis catalogue, but it has immediately become a new strong suit for the brand, performing in an unprecedented creative melting pot to give a concerted portrayal of contemporary living. In a more intimate part of the stand, hidden by the central wall on which the Magis logo is emblazoned, are two new lamp collections designed by BrogliatoTraverso: Lost, which plays on the perfection of a circle, and Bouquet, the mini lamp/flower vase.

A world of interiors that is unpredictable and bold, yet also versatile and timeless. And this is what makes it democratic. Magis products do not have just one use, but many stylistic interpretations.

Plastics, metals, fabrics, recyclable and recycled materials come together to outline domestic and contract settings with a versatile spirit that weaves together informal, fluid atmospheres. Tables, upholstered furniture, chairs, bookcases, ornaments and accessories move with ease from the living room to the office, from the bedroom to outdoor spaces, from the kitchen to the bathroom, with a creative vision that looks to the future.

The Magis house expresses the pleasure of living. With many new features and an ever-evolving style.

MAGIS

Magis @ Milano Design Week
07 / 12 June 2022



Aka design Konstantin Grcic



AKA is part chair, part stool, part sculpture. In beech plywood, available in a natural finish or in two colour variations, Konstantin Grcic's new experiment hybridises the functionality of two seats into a rigorous geometry.

Also Known As... Stool, AKA showcases the designer's great furniture-making expertise and his absolute drive for sustainability.

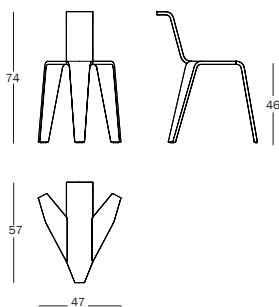
Once again, Grcic's humanistic approach to design is paired with a formal rigour to give us a simple object that interprets the fundamentals of design with intelligence and a hint of irony.



Stool in aniline-dyed beech

-  natural
-  stained black
-  stained petrol blue

MAGIS

Magis @ Milano Design Week
07 / 12 June 2022



Alpina design Edward Barber & Jay Osgerby

Alpina, designed by British designers Edward Barber and Jay Osgerby, defines a new archetype for chairs from a perspective of all-round sustainability.

The chair is inspired by a classical model of the alpine furniture tradition. Edward Barber and Jay Osgerby have created a new chair, reminiscent of an alpine stool, that is elegant and versatile, capable of adapting to both traditional and more contemporary environments. Simple and clean, yet curvaceous and enveloping, the new chair combines a solid ash wood frame (FSC certified) with an injection moulded backrest in bio-based polypropylene that derives fully from waste cooking oils. Fully recyclable.

Alpina is the fourth project by Barber Osgerby for Magis. Alpina celebrates their multidisciplinary approach, a penchant for experimentation and a desire to juxtapose clean lines and different materials. The collaboration with Barber Osgerby started in 2007 with Birds on a Wire hanging system and continued in 2010 with the design of Four Leaves coat stand and Poppins umbrella stand.

Alpina is available in three variations: natural ash seat and legs with an olive green backrest, natural ash seat and legs with a beige backrest, black ash seat and legs with a black backrest. Suitable for both domestic and contract use.

MAGIS

Magis @ Milano Design Week
07 / 12 June 2022



Alpina design Edward Barber & Jay Osgerby

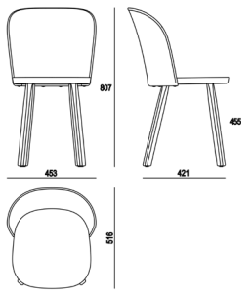

Seat and legs in solid ash



natural



stained black

Back in polypropylene



olive green 1791 C



beige 1792 C



black 1793 C

MAGIS

Magis @ Milano Design Week
07 / 12 June 2022



Bouquet design BrogliatoTraverso

Bouquet is a portable table lamp that doubles as a flower vase.

Available in six monochromatic colours which offer several possible combinations thanks to the removable flower vase.

Designed by BrogliatoTraverso, who founded their design studio of the same name in 2014, this small rechargeable lamp reflects the duo's modus operandi: simplify and design essential objects, minimising details and maximising functionality to offer unexpected solutions for use.

Thus, light becomes the unexpected decorative element in floral arrangements. Suitable for indoor and outdoor use, it creates the perfect atmosphere.

MAGIS

Magis @ Milano Design Week
07 / 12 June 2022



Bouquet design BrogliatoTraverso

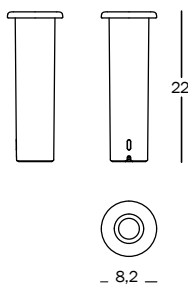

red

black

lime green

caramel

light blue

white

MAGIS

Magis @ Milano Design Week
07 / 12 June 2022



Lost design BrogliatoTraverso

Lost is Magis' first lamp collection.

Empty spaces are the key to Lost. The lamp focuses on the perfection of a circle in an essential graphic divertimento.

BrogliatoTraverso replace the classic lampshade with a circle just 2 cm thick, which conceals an adjustable LED light source.

The result is an even, continuous illumination around the entire circumference, topped off with a simple stem.

Available in suspended, floor, ceiling/wall and table-top versions, Lost offers an archetype of Studio BrogliatoTraverso's distinctive "no time, no space" design: a timeless, purist aesthetic that fits perfectly into any setting.

Almost invisible, yet full of character, Lost turns empty space into magic, creating a dreamlike, contemporary atmosphere.

MAGIS

Magis @ Milano Design Week
07 / 12 June 2022



Lost design BrogliatoTraverso

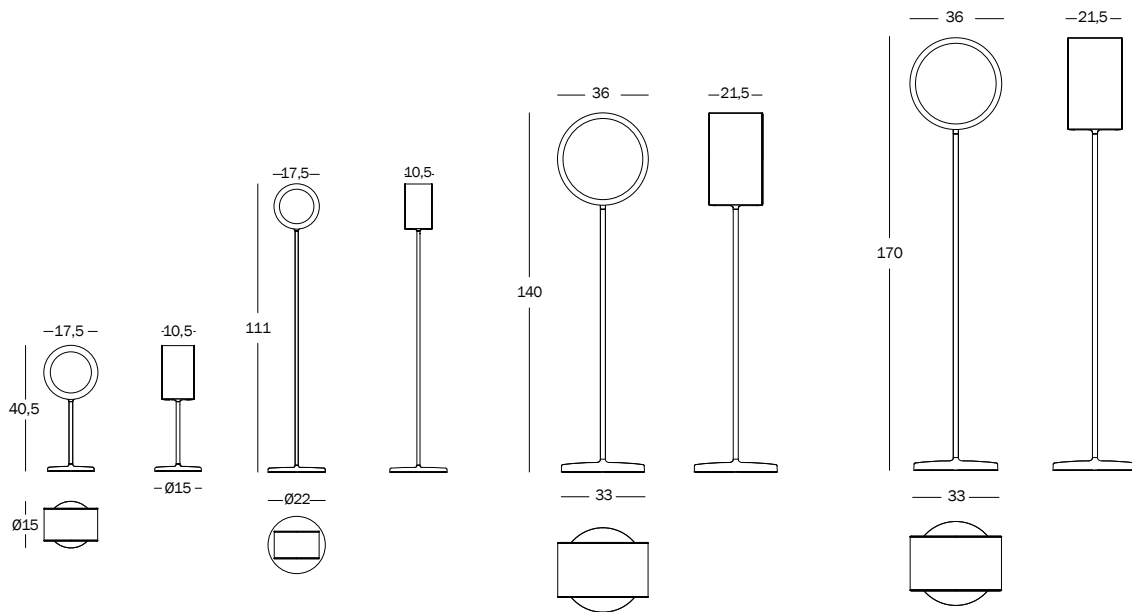
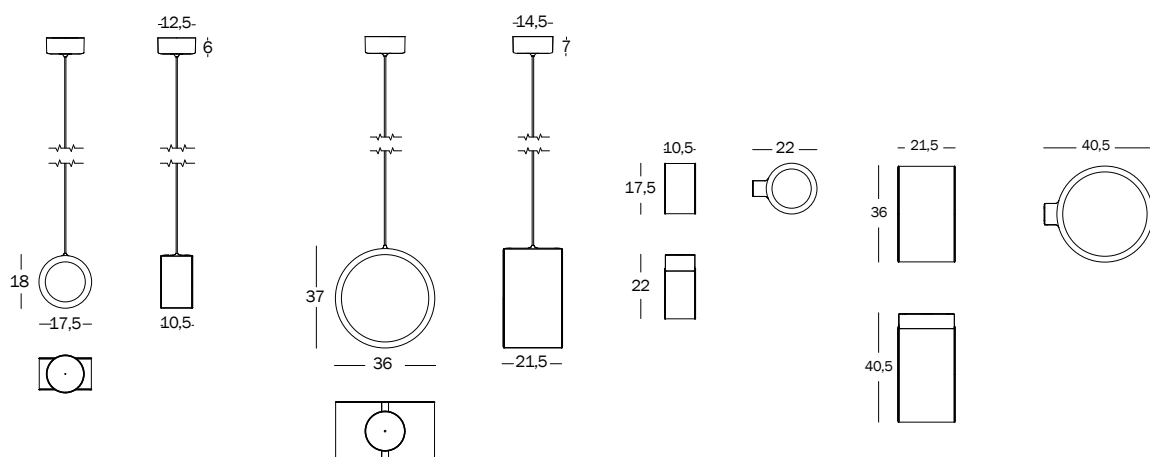

Table Lamp

Floor Lamp S

Floor Lamp M

Floor Lamp L



Suspension Lamp
S

Suspension Lamp
L

Wall and Ceiling
Lamp S

Wall and Ceiling
Lamp L

Lamp



black 5140

MAGIS

Magis @ Milano Design Week
07 / 12 June 2022

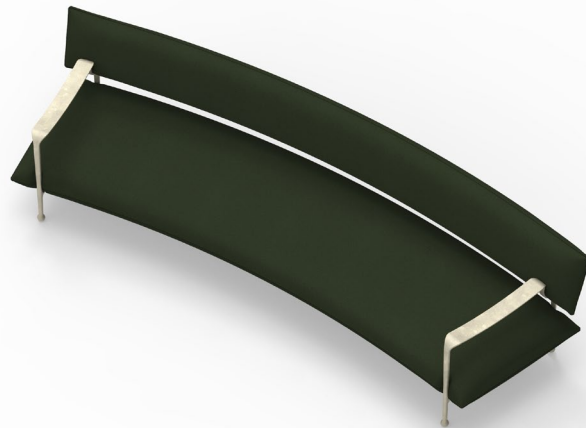

Riace design Ronan & Erwan Bouroullec

Ronan & Erwan Bouroullec once again create a new sofa playing on contrasting lines and volumes.

Riace, an ode to the beauty of the town with its famous Warrior statues, is a short-circuit of dynamic rigour.

Equally sculptural and sinuous, the Riace sofa has a slender white bronze frame supporting a seemingly-suspended, wide upholstered seat and backrest.

It comes in one size and shape only, while the fabric covers can be changed to suit different furnishing needs. Riace fits perfectly well in both residential and contract environments.

Once again, an impeccable balance between seriousness and lightness defines the style of the two designers, creating an instantly familiar, exciting and vibrant atmosphere.

To impress, but without excess.

MAGIS

Magis @ Milano Design Week
07 / 12 June 2022



Swing design Ron Gilad

Ron Gilad transforms the partition into a theatrical backdrop that can be moved to create one or many secluded spaces.

Swing is a versatile partition screen that opens and closes easily on a central axis: comprising four pivoting panels, it can be passed through like a door or closed where needed to produce a temporary subdivision within any space.

The panels are sound absorbing and made in flame resistant polyester felt. Frame in anodized aluminium.

The panels are available in three colours.

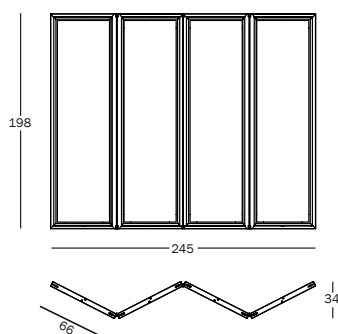

Frame in aluminium

anodized natural

Panels in flame retardant polyester colc



anthracite



beige



light blue

MAGIS

Magis @ Milano Design Week
07 / 12 June 2022



Tambour design Ronan & Erwan Bouroullec

Another range extension from Ronan & Erwan Bouroullec.

Designed in 2012 and made in die-cast aluminium, this year we are relaunching Tambour coffee tables in a new variant with a top in stoneware.

Created to fit in anywhere, these new coffee tables can also explore outdoor spaces.

The legs are in die-cast aluminium: polished (for indoor use) or painted in polyester powder (for outdoor use). Available in two different heights and in a range of various table tops shapes and colours.

MAGIS

Magis @ Milano Design Week
07 / 12 June 2022



Tambour design Ronan & Erwan Bouroullec

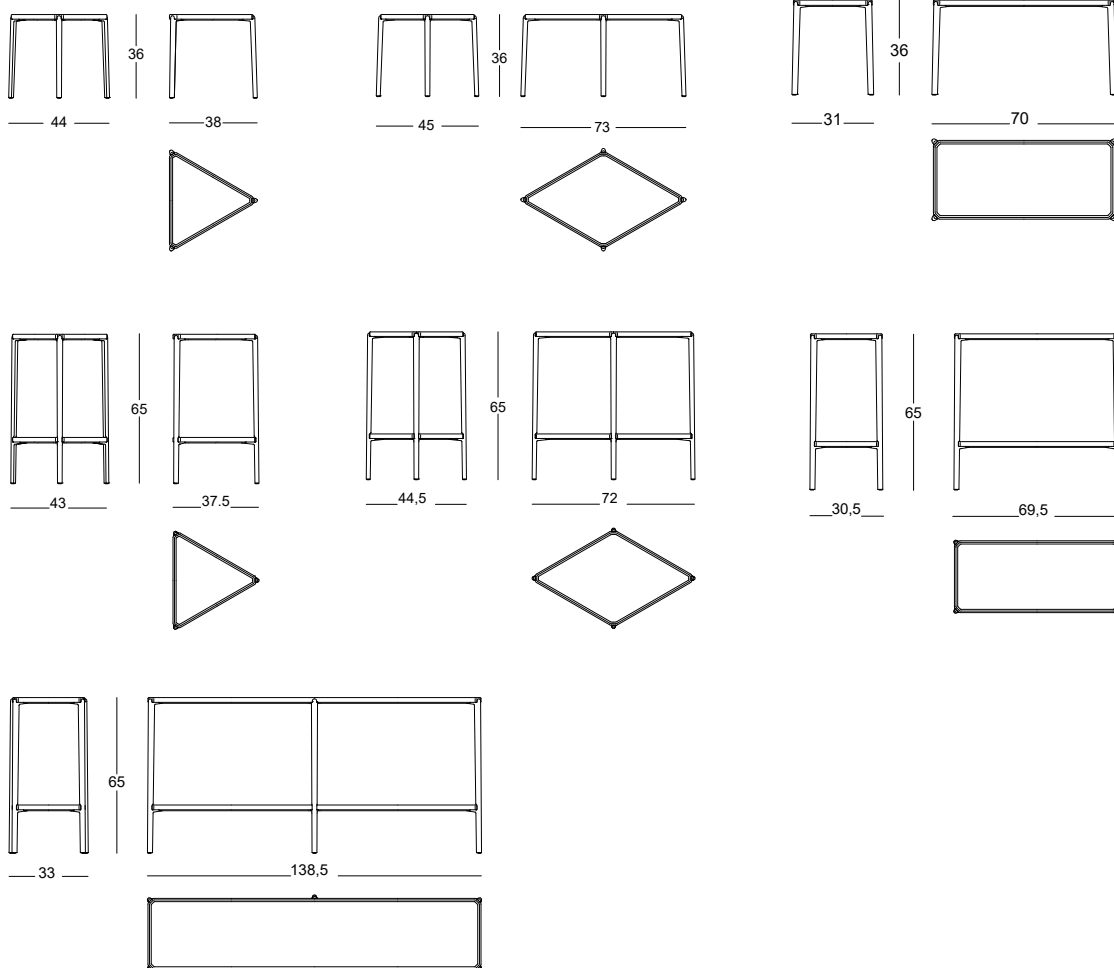

Frame in aluminium

Top in gres

polished

white

white 5108

green

light blue

terracotta

MAGIS

Magis @ Milano Design Week
07 / 12 June 2022



Costume design Stefan Diez

Modular, devoted to comfort and the environment: Costume, the sofa collection designed by Stefan Diez for Magis in 2019, fits perfectly well in both domestic and contract environments. Its innovative design revolutionises the concept of contemporary seating. Made of recycled and recyclable 4-mm-thick polyethylene, Costume can be dressed in different fabrics and create innumerable compositions to meet any interior design needs.

The concept is simple: essential modules that can be accessorised with armrests that fold inward, and an ottoman, all with fully removable covers that can be combined in every way imaginable. Ultimate versatility, absolute sustainability.

This year Costume expands further with the addition of two low tables in folded aluminium plate, powder coated. The low tables are conceived to be placed between two seating units or ottoman (not as ending units of a seating composition). Power supply available on request.

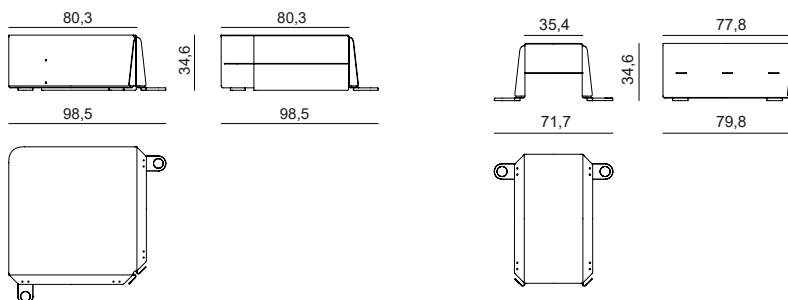

Powder coated aluminum sheet

black

MAGIS

Magis @ Milano Design Week
07 / 12 June 2022

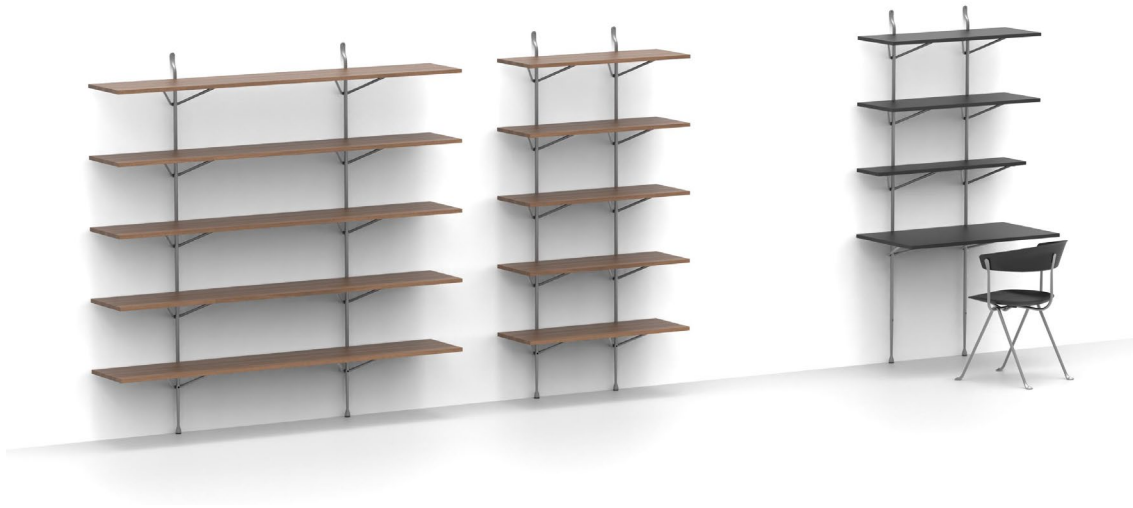

Officina design Ronan & Erwan Bouroullec

The Officina collection explores a new creative language through the ancient fabrication process that is iron forging.

Designed by Ronan & Erwan Bouroullec in 2014 and started with tables, this year we are introducing a wall-mounted bookcase.

The strong suits of this neat, rigorous set of furniture are its clean lines and extreme functionality, but it also has a lightness that adds a remarkable, dynamic sense of momentum.

The distinctive language of forged iron, the key feature of the entire Officina collection, is echoed in the essential anthracite grey frame, finished off with shelves in mass coloured black MDF or walnut.

Shelves are available in two dimensions: 1 metre and 2 metres long.

The 1 metre long version also comes with a writing desk top.

MAGIS

Magis @ Milano Design Week
07 / 12 June 2022



Officina design Ronan & Erwan Bouroullec

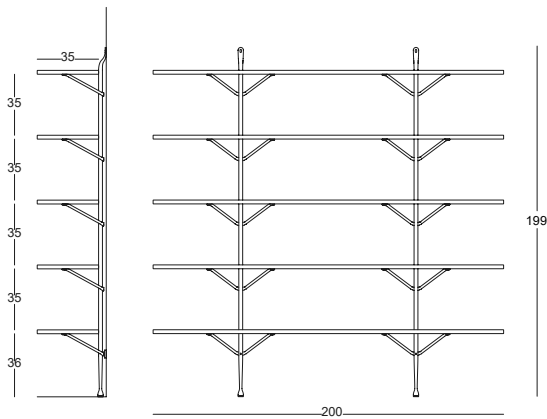
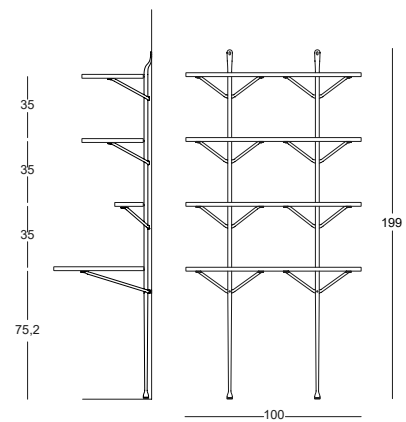
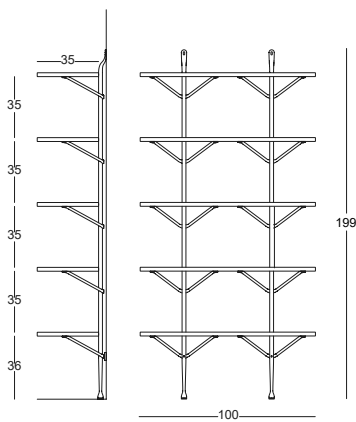

Frame in wrought iron

grey anthracite 5142

Shelves in MDF

Fibralex painted black



walnut veneered

MAGIS

Magis @ Milano Design Week
07 / 12 June 2022



Big Will design Philippe Starck

The iconic Big Will table by Philippe Starck also gets a revamp.

First made almost 10 years ago with the aim of creating an unconventional extending table, Big Will once again marks a new chapter in Magis' creativity.

Made of die-cast aluminium, it has always been ahead of its time, offering the perfect combination of function and style: one side has conventional feet, while the other side has two wheels, again in die-cast aluminium, which allow it to be easily extended by simply sliding the one end out.

Today it gets a makeover with three new finishes: stoneware with a polished Calacatta marble finish, stoneware with a polished Marquinia marble finish, and white wood. Understated, modern and ingenious as ever.

MAGIS

Magis @ Milano Design Week
07 / 12 June 2022



Big Will design Philippe Starck

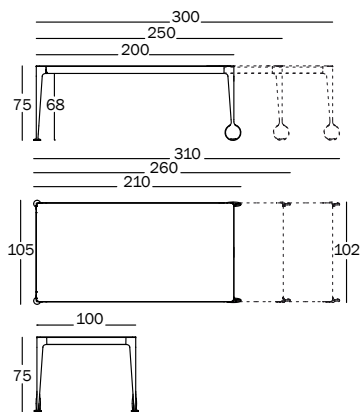

Frame in aluminium



white 5110

black 5130

Top

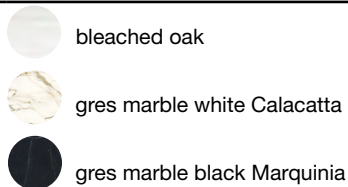

bleached oak

gres marble white Calacatta

gres marble black Marquinia

Wheels in rubber



black

grey

Leaf in MDF



white 8500

black 8510

MAGIS

Magis @ Milano Design Week
07 / 12 June 2022



press@magisdesign.com